

MANDATORY**SEL-57-06****TITLE**

WINGS - MODEL 210 CARRY-THRU SPAR ONE-TIME EDDY CURRENT INSPECTION

EFFECTIVITY

MODEL	SERIAL NUMBERS
210G	21058819 thru 21058936
T210G	T210-0198 thru T210-0307
210H	21058937 thru 21059061
T210H	T210-0308 thru T210-0392
210J	21059062 thru 21059199
T210J	21058140, T210-0393 thru T210-0454
210K	21059200 thru 21059502
T210K	21059200 thru 21059502
210L	21059503 thru 21061573
T210L	21059503 thru 21061573
210M	21061574 thru 21062954
T210M	21061574 thru 21062954
210N	21062955 thru 21064897
P210N	P21000001 thru P21000834
T210N	21062955 thru 21064897
210R	21064898 thru 21065009
P210R	P21000835 thru P21000874
T210R	21064898 thru 21065009

REASON

The carry-thru spar can develop corrosion and cracks. Corrosion can propagate and lead to crack development. A crack in the carry-thru spar can develop to a point that the carry-thru spar can have structural failure that can result in subsequent loss of airplane control and/or wing separation.

Non-compliance with this service letter may result in undetected crack(s) in the carry-thru spar, which can result in structural failure of the carry-thru spar.

DESCRIPTION

This service document provides instructions to do a detailed visual inspection and an eddy current inspection of the lower surface of the carry-thru spar.

June 24, 2019

SEL-57-06
Page 1 of 10

Textron Aviation Customer Service, P.O. Box 7706, Wichita, KS 67277, U.S.A. 1-316-517-5800

This document contains technical data and is subject to U.S. export regulations. This information has been exported from the United States in accordance with export administration regulations. Diversion contrary to U.S. law is prohibited. ECCN: 9E991

MANDATORY**SEL-57-06****COMPLIANCE**

WARNING: The Carry-Thru spar inspection presented in this service letter applies to airplanes listed in the Effectivity Section. The compliance time is for unmodified airplanes, and represents the maximum allowable time. Airplanes that have been modified to alter the airplane design, gross weight, or airplane performance, may need to inspect sooner. Examples of common supplemental type certificates (STC's) include vortex generators, wing cuffs, STOL kits, wing tips, and add-on wing fuel tanks. Contact the STC holder for revised inspection intervals.

MANDATORY. This service document must be accomplished within 10 flight hours from date of receipt as follows:

NOTE: Refer to the applicable service and maintenance manual, Section 2A-10-00, Inspection Time Limits - Structure for a description of SEVERE and TYPICAL usage environment to determine the correct usage criteria for the airplane.

If the history of the airplane operation is unknown, use the SEVERE usage as a determination for flight hours compliance.

- **For airplanes flown in SEVERE Usage as defined in Section 2A-10-00:**
 - Airplanes that have more than 1,500 flight hours must accomplish this document within 10 flight hours.
 - Airplanes that have less than 1,500 flight hours must accomplish this document within 10 flight hours upon reaching 1,500 flight hours.
 - It is acceptable to accomplish this service document before 1,500 hours to align with a scheduled maintenance event or inspection.
- **For airplanes flown in TYPICAL Usage as defined in Section 2A-10-00:**
 - Airplanes that have more than 4,000 flight hours must accomplish this document within 10 flight hours.
 - Airplanes that have less than 4,000 flight hours must accomplish this document within 10 flight hours upon reaching 4,000 flight hours.
 - It is acceptable to accomplish this service document before 4,000 flight hours to align with a scheduled maintenance event or inspection.

A service document published by Textron Aviation may be recorded as *completed* in an aircraft log only when the following requirements are satisfied:

- 1) The mechanic must complete all of the instructions in the service document, including the intent therein.
- 2) The mechanic must correctly use and install all applicable parts supplied with the service document kit. Only with written authorization from Textron Aviation can substitute parts or rebuilt parts be used to replace new parts.
- 3) The mechanic or airplane owner must use the technical data in the service document only as approved and published.
- 4) The mechanic or airplane owner must apply the information in the service document only to aircraft serial numbers identified in the *Effectivity* section of the document.
- 5) The mechanic or airplane owner must use maintenance practices that are identified as acceptable standard practices in the aviation industry and governmental regulations.

No individual or corporate organization other than Textron Aviation is authorized to make or apply any changes to a Textron Aviation-issued service document or flight manual supplement without prior written consent from Textron Aviation.

Textron Aviation is not responsible for the quality of maintenance performed to comply with this document, unless the maintenance is accomplished at a Textron Aviation-owned Service Center.

MANDATORY

SEL-57-06

CONSUMABLE MATERIAL

You must use the consumable materials that follow, or their equivalent, to complete this service document.

NAME	NUMBER	MANUFACTURER	USE
Cor-Ban 23	COR-BAN-23 (U074098) (12oz aerosol)	Textron Aviation Parts Distribution 7121 Southwest Boulevard Wichita, KS 67215	Corrosion Inhibiting Compound coating
Formit-18 Fan	Formit-18	Textron Aviation Parts Distribution	Nozzle for Cor-Ban 23 application
Corrosion Resistant Primer	K000574 (2oz Kit)	Textron Aviation Parts Distribution	Preferred corrosion resistant epoxy primer
Color Chemical Film Treatment	1445846 (Alodine 1132 Touch n Prep Pen)	Textron Aviation Parts Distribution	To prepare aluminum surface for intermediate primer.
Methyl Propyl Ketone	TT-I-735	Commercially Available	Cleaning solvent for Corban Corrosion Inhibiting Compound.
Isopropyl Alcohol	TT-I-735	Commercially Available	Type I Cleaning Solvent for surface cleaning prior to painting
Aluminum oxide paper or cloth (high purity) - 180 and 220 or 320 grit		Commercially Available	To remove paint before inspection and surface preparation before painting
Extreme Simple Green Aircraft and Precision Cleaner		Commercially Available	To be used for cleaning soiled surface

CAUTION: Do not use any other Simple Green products other than Extreme Simple Green as some have been found to be corrosive.

NOTE: Textron Aviation has also tested and approved Cor-Ban 35 and ARDROX AV-8. These products may be used in place of Cor-Ban 23 at the owners discretion.

TOOLING

NAME	NUMBER	MANUFACTURER	USE
10X Magnifying Lense		Commercially Available	For detailed visual inspection of carry-thru spar.
Eddy Current Inspection Equipment		Nondestructive Inspection Methods and Requirements, Document 2A-13-01 found in Section 2A Supplemental Inspection Documents in the appropriate Model Service or Maintenance Manual	For Eddy Current inspection of carry-thru spar lower surface.

REFERENCES

- Cessna Model 200 Series (1966-1968) Service Manual
- Cessna Model 210 Centurion Series (1969) Service Manual
- Cessna Model 210 Centurion Series (1970-1976) Service Manual
- Cessna Model 210 and T210 Series (1977-1984) Service Manual

MANDATORY**SEL-57-06**

Cessna Model 210 and T210 Series (1985-1986) Service Manual

Cessna Model P210 Series (1978-1983) Service Manual

Cessna Model P210 Series (1985-1986) Service Manual

Inspection Time Limits - Structure, Section 2A-10-00 found in Section 2A Supplemental Inspection Documents in the appropriate Model Service or Maintenance Manual,

Nondestructive Inspection Methods and Requirements, Document 2A-13-01 found in Section 2A Supplemental Inspection Documents in the appropriate Model Service or Maintenance Manual

NOTE: To make sure all publications used are complete and current. Refer to www.txtavsupport.com.

PUBLICATIONS AFFECTED

None

ACCOMPLISHMENT INSTRUCTIONS

1. Prepare the airplane for maintenance.
 - A. Make sure that the airplane is electrically grounded.
 - B. Make sure that all switches are in the OFF/NORM position.
 - C. Disconnect electrical power from the airplane.
 - (1) Disconnect external electrical power.
 - (2) Disconnect the airplane battery.
 - D. Attach maintenance warning tags to the battery and external power receptacle that have "**DO NOT CONNECT ELECTRICAL POWER - MAINTENANCE IN PROGRESS**" written on them.
2. Remove the pilot and co-pilot seats. (Refer to the applicable Model Service or Maintenance Manual.)
3. Get access to the lower surface of the carry-thru spar by removing upholstery, headliner, and installed utility or oxygen systems as necessary. (Refer to the applicable Model Service or Maintenance Manual.)
4. If installed, Remove foam from bottom of carry-thru spar as applicable.
 - A. Clean all adhesive residue from the carry-thru spar.
5. Clean the lower surface of the carry-thru spar of grime or debris.
6. (Refer to Figure 1, Sheets 1-3.) Use a 10X magnification lens to do a detailed visual inspection of the carry-thru spar for corrosion with particular attention to the locations as follows:
 - Where support wires in the air duct contact the structure.
 - Where upholstery pads contact the spar.

NOTE: A detailed visual inspection is described as an intensive visual examination of a specific structural area, system, installation, or assembly to detect damage, failure, or irregularity. Available lighting is normally supplemented with a direct source of good lighting at an intensity deemed appropriate by the inspector. Inspection aids such as mirrors, magnifying lenses, borescopes etc. may be used. Surface cleaning and elaborate access procedures such as panel or component removal, may be necessary.

- A. If corrosion is found on the carry-thru spar, the area can be reworked as follows:
 - (1) Use 180 grit or finer aluminum oxide abrasive paper, cloth or pads to carefully remove corrosion and blend that area locally around the affected region.
 - (2) Make sure to only remove the minimum material necessary to blend the corroded surface with the surrounding surface.
 - (3) Maintain a minimum of 20:1 blend to depth ratio.
 - (4) Leave no sharp edges after blending.

MANDATORY**SEL-57-06**

- (5) Finish with a 220 grit or finer grained aluminum oxide sandpaper.
 - (6) Use clean dry air to blow off dust.
 - (7) Use a clean cloth wet with isopropyl alcohol to clean the surface.
 - (8) Measure the blended area and contact Textron Aviation Structures with the dimension of blended area for evaluation. (Refer to the Carry-Thru Spar Inspection Report for contact information.)
 - (9) Complete the eddy current inspection, go to Step 7.
- B. If no corrosion is found on the carry-thru spar, complete the eddy current inspection, go to Step 7.
7. (Refer to Figure 1, View A-A.) Do an eddy current inspection of the carry-thru spar as follows: (Refer to 2A-13-01, Nondestructive Inspection Methods and Requirements in the appropriate Model Service or Maintenance Manual.)
- A. Plan out the inspection process to cover the items listed as follows:
 - If the eddy current inspection is performed by qualified personnel that are not representing an FAA Certified Repair Station, an A&P Mechanic may supervise the inspection and make the appropriate logbook entry.
 - Technician must be Level 2 certified.
 - Eddy current inspection will cover the lower service of the carry-thru spar starting as far outboard on either side as reachable inside the fuselage.
 - Eddy current inspection will be with a 0.125-inch probe.
 - Technician should use an inspection approach that ensures the entire surface is inspected without gaps.
 - One example of a technique is to inspect small equally spaced sections, no wider than 4 inches.
 - Inspect one section at a time and overlap each section by 0.25-inch. overlap between each section and identify when each section is complete.
 - Identify when each section is complete to help keep track of progress.
 - B. Review the General Requirements and Eddy Current Inspection sections of 2A-13-01 Nondestructive Inspection Methods and Requirements.
 - C. Calibrate the eddy current instrument - Impedance Plane. (Refer to 2A-13-01, Nondestructive Inspection Methods and Requirements, Section 2. Eddy Current Inspection.)
 - D. Eddy current scan the surface with an 0.125-inch diameter surface pencil probe at 200 kHz.
 - Scan direction must be with an inboard to outboard direction.
 - Use of a non-metallic straight edge as a guide will help ensure there is not a fore-aft motion of the probe.
 - Probe one small section of only a couple of inches at a time, recommend no wider than 4-inches.
 - Move the probe in 0.125-inch increments.
 - Overlap each section by 0.25-inch.
 - Use of a slow controlled methodical process to make sure the entire surface is covered.
- (1) Start the inspection in the center of the carry-thru spar and work from inboard to outboard in small methodically controlled sections with a 0.25-inch overlap until as far outboard as reachable inside the fuselage then repeat the process for the other half of the carry-thru spar.
 - (2) Look for a sharp response of 10-percent screen height or more may indicate corrosion or fatigue cracking or both.
- E. If you find one or more cracks, further flight is **NOT** permitted. You must replace the carry-thru spar before further flight.

MANDATORY**SEL-57-06**

- F. Provide the results of the detailed visual and eddy current inspections to Textron Aviation, Structural Repair. Use the Carry-Thru Spar Inspection Report form and pictures as applicable. Telephone number and email address are provided on the form.

NOTE: The Carry-Thru Spar Inspection Report form must be sent to Textron Aviation, Structural Repair to report all conditions, cracks, corrosion, or no cracks or no corrosion.

8. If there has been rework, apply Color Chemical Film Treatment to the bare aluminum surface.
9. If there has been rework, apply Corrosion Resistant Epoxy Primer to all bare metal.
10. Apply Corrosion Inhibiting Compound (CIC) to the entire lower surface of the carry-thru spar that is accessible in the fuselage as follows: (Refer to SEL-51-01 Standard Practices - Structures - Use of Corrosion Inhibiting Compounds.)

NOTE: SEL-51-01 is a resource that provides additional detailed information about the application process of CIC such as equipment, facility, cleaning, masking, and application processes.

- A. Mask areas around the carry-thru spar areas to prevent over spray of the CIC.
- B. Spray aerosol with extension tube to minimize over spray.
- C. Apply the CIC in one full wet coat.
- D. Apply CIC to the full lower surfaces of the carry-thru spar.
- E. Some sag/run is acceptable. A spot of significant sag/run needs to be cleaned by MPK (methyl propyl ketone) wiping and the CIC shall be reapplied.
- F. Wet film thickness of CIC is approximately 1 to 2 mils for Cor-Ban 23.
- NOTE:** The coating should be tack-free after two to three hours.
- G. After the CIC coating is tack-free, remove the masking from around the application area.
- H. Let the CIC coating cure with a minimum cure temperature no less than 50 degrees F.
11. Install removed utility systems, oxygen systems, headliner and upholstery that was removed to access the carry-thru spar. (Refer to the applicable Model Service or Maintenance Manual.)
12. Install the pilot and co-pilot seats. (Refer to the applicable Model Service or Maintenance Manual.)
13. Remove the maintenance warning tags and connect the airplane battery.
14. Make an entry in the airplane logbook that states compliance and method of compliance with this service document.

MANDATORY

SEL-57-06

B21851

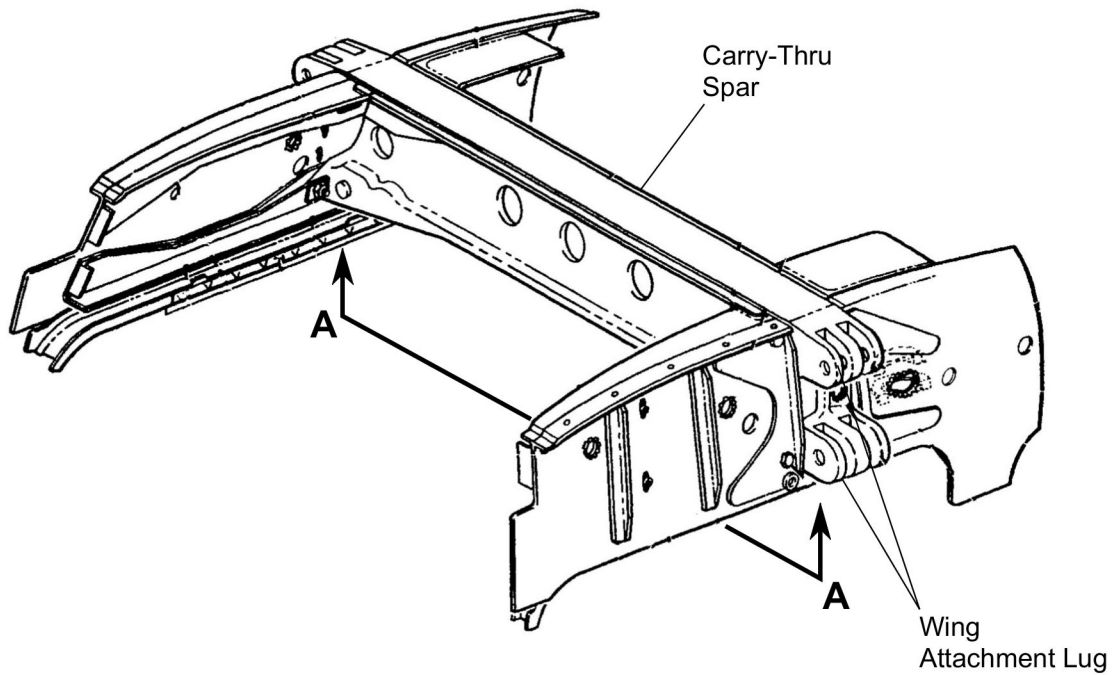
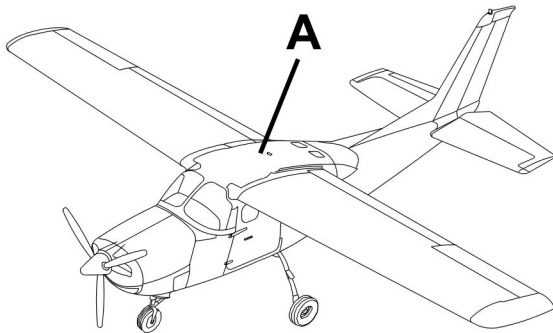

DETAIL A

Figure 1. Carry-Thru Spar Inspection (Sheet 1)

1210T1036
A1210X1037

MANDATORY

SEL-57-06

B21852

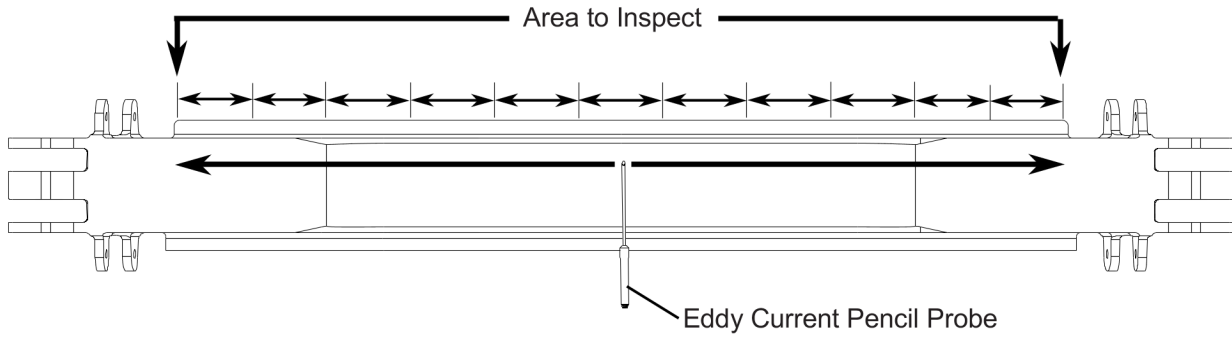

VIEW A-A

View Looking Up at Lower Surface of the Carry-Thru

NOTE: Eddy Current Pencil Probe motion of travel is center to outboard while working small equally spaced overlapping sections. Illustration shows equally spaced sections as an example. The Eddy Current Inspection will cover the entire lower surface of the carry-thru spar that is accessible inside the fuselage.

2110068-1

Figure 1. Carry-Thru Spar Inspection (Sheet 2)

MANDATORY

SEL-57-06

B21853

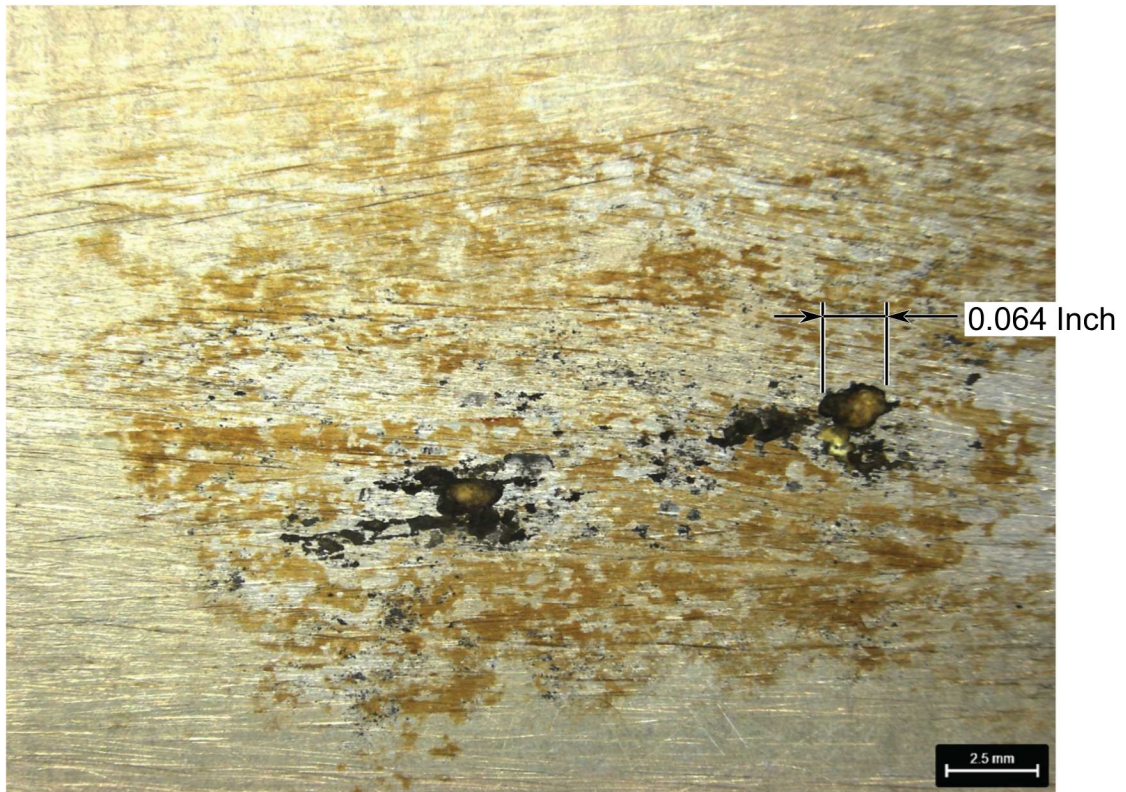

Corrosion on Lower Surface of Carry-Thru Spar

NOTE: Image not to scale.

Figure 1. Carry-Thru Spar Inspection (Sheet 3)

MANDATORY

SEL-57-06

MATERIAL INFORMATION

No parts are required to complete this service document.

TITLE

WINGS - MODEL 210 CARRY-THRU SPAR ONE-TIME EDDY CURRENT INSPECTION

TO:

Cessna Model 210 Aircraft Owner

REASON

The carry-thru spar can develop corrosion and cracks. Corrosion can propagate and lead to crack development. A crack in the carry-thru spar can develop to a point that the carry-thru spar can have structural failure that can result in subsequent loss of airplane control and/or wing separation.

Non-compliance with this service letter may result in undetected crack(s) in the carry-thru spar, which can result in structural failure of the carry-thru spar.

COMPLIANCE

WARNING: The Carry-Thru spar inspection presented in this service letter applies to airplanes listed in the Effectivity Section. The compliance time is for unmodified airplanes, and represents the maximum allowable time. Airplanes that have been modified to alter the airplane design, gross weight, or airplane performance, may need to inspect sooner. Examples of common supplemental type certificates (STC's) include vortex generators, wing cuffs, STOL kits, wing tips, and add-on wing fuel tanks. Contact the STC holder for revised inspection intervals.

MANDATORY. This service document must be accomplished within 10 flight hours from date of receipt as follows:

NOTE: Refer to the applicable service and maintenance manual, Section 2A-10-00, Inspection Time Limits - Structure for a description of SEVERE and TYPICAL usage environment to determine the correct usage criteria for the airplane.

If the history of the airplane operation is unknown, use the SEVERE usage as a determination for flight hours compliance.

- **For airplanes flown in SEVERE Usage as defined in Section 2A-10-00:**
 - Airplanes that have more than 1,500 flight hours must accomplish this document within 10 flight hours.
 - Airplanes that have less than 1,500 flight hours must accomplish this document within 10 flight hours upon reaching 1,500 flight hours.
 - It is acceptable to accomplish this service document before 1,500 hours to align with a scheduled maintenance event or inspection.
- **For airplanes flown in TYPICAL Usage as defined in Section 2A-10-00:**
 - Airplanes that have more than 4,000 flight hours must accomplish this document within 10 flight hours.
 - Airplanes that have less than 4,000 flight hours must accomplish this document within 10 flight hours upon reaching 4,000 flight hours.
 - It is acceptable to accomplish this service document before 4,000 flight hours to align with a scheduled maintenance event or inspection.

June 24, 2019

SEL-57-06
Page 1 of 2

Textron Aviation Customer Service, P.O. Box 7706, Wichita, KS 67277, U.S.A. 1-316-517-5800

This document contains technical data and is subject to U.S. export regulations. This information has been exported from the United States in accordance with export administration regulations. Diversion contrary to U.S. law is prohibited. ECCN: 9e991

LABOR HOURS

For planning purposes only:

WORK PHASE	LABOR-HOURS
Inspection	As Necessary

WARRANTY

None

NOTE: As a convenience, service documents are now available online to all our customers through a simple, free-of-charge registration process. If you would like to sign up, please visit the Customer Access link at www.txtavsupport.com to register.